

Manual Cutting Mill SM100

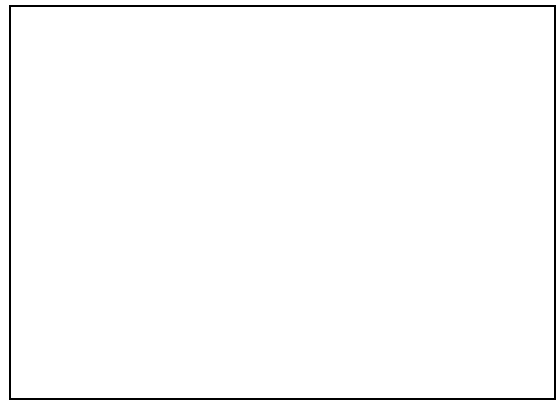

Translation

Retsch[®]

Copyright

© Copyright by
Retsch GmbH
Retsch-Allee 1-5
42781 Haan
Germany

Table of Contents

1	Notes on the Manual	6
1.1	Explanations of the Safety Instructions	7
1.2	General Safety Instructions	8
1.3	Repairs.....	9
2	Confirmation	10
3	Packaging, Transport and Installation	11
3.1	Packaging	11
3.2	Transport.....	11
3.3	Temperature fluctuations and condensed water	11
3.4	Conditions for the Installation Site	11
3.5	Electrical Connection	12
3.6	Type Plate Description.....	13
3.7	Removing the Transportation Aid	14
3.8	Frame assembly	15
3.9	Mounting the Feed Hopper	19
3.9.1	Removing the Transport Safeguard	19
3.9.2	Mounting the Feed Hopper	20
3.10	Installation of the Device.....	21
3.11	Height adjustment and alignment of the support structure	21
4	Technical Data	24
4.1	Use of the Device for the Intended Purpose.....	24
4.2	Emissions.....	25
4.3	Degree of Protection.....	25
4.4	Motor rotation speed.....	25
4.5	Receptacle Volume.....	25
4.6	Rated Power	25
4.7	Dimensions and Weight.....	26
4.8	Required Floor Space	26
4.9	Note on the motor	27
5	Operating the Device	28
5.1	Views of the Instrument	28
5.2	Overview table of the parts of the device	30
5.3	Opening and Closing of the Device	31
5.4	Mounting the bottom sieve.....	31
5.5	Replacing the rotor	31
5.5.1	Removing the Rotor	32
5.5.2	Inserting the Rotor	32
5.6	Inserting the filter unit and collecting receptacle.....	33
5.7	Switching On and Off.....	34
5.8	Starting the grinding process	34
5.9	Stopping the grinding process	34
6	Cleaning and service	35
6.1	Adjusting the cutting bars	35
6.2	Cleaning.....	37
6.2.1	Clean the feed hopper	38
6.2.1.1	Lift up the feed hopper safety guard.....	39
6.2.1.2	Remove the feed hopper	40
6.2.1.3	Mount the feed hopper.....	40
6.2.2	Clean grinding area	41
6.2.3	Remove the discharge flange	41
7	Disposal.....	42
8	Index	43

1 Notes on the Manual

This operating manual is a technical guide on how to operate the device safely and it contains all the information required for the areas specified in the table of contents. This technical documentation is a reference and instruction manual. The individual chapters are complete in themselves.

Familiarity (of the respective target groups defined according to area) with the relevant chapters is a precondition for the safe and appropriate use of the device.

This operating manual does not contain any repair instructions. If faults arise or repairs are necessary, please contact your supplier or get in touch with Retsch GmbH directly.

Application technology information relating to samples to be processed is not included but can be read on the Internet on the respective device's page at www.retsch.com.

Changes

Subject to technical changes.

Copyright

Disclosure or reproduction of this documentation, use and disclosure of its contents are only permitted with the express permission of Retsch GmbH.

Infringements will result in damage compensation liability.

1.1 Explanations of the Safety Instructions

In this Operating Manual we give you the following safety warnings

Serious injury may result from failing to heed these safety warnings. We give you the following warnings and corresponding content.

 **WARNING**

Type of danger / personal injury

Source of danger

- Possible consequences if the dangers are not observed.
 - **Instructions on how the dangers are to be avoided.**
-

We also use the following signal word box in the text or in the instructions on action to be taken:

 **WARNING**

Moderate or mild injury may result from failing to heed these safety warnings. We give you the following warnings and corresponding content.

 **CAUTION**

Type of danger / personal injury

Source of danger

- Possible consequences if the dangers are not observed.
 - **Instructions on how the dangers are to be avoided.**
-

We also use the following signal word box in the text or in the instructions on action to be taken:

 **CAUTION**

In the event of possible **property damage** we inform you with the word “Instructions” and the corresponding content.

NOTICE

Nature of the property damage

Source of property damage

- Possible consequences if the instructions are not observed.
 - **Instructions on how the dangers are to be avoided.**
-

We also use the following signal word in the text or in the instructions on action to be taken:

NOTICE

1.2 General Safety Instructions



CAUTION

Read the Operating Manual

Non-observance of these operating instructions

- The non-observance of these operating instructions can result in personal injuries.
- **Read the operating manual before using the device.**
- **We use the adjacent symbol to draw attention to the necessity of knowing the contents of this operating manual.**



Target group : All persons concerned with the machine in any form

This machine is a modern, high performance product from Retsch GmbH and complies with the state of the art. Operational safety is given if the machine is handled for the intended purpose and attention is given to this technical documentation.

You, as the owner/managing operator of the machine, must ensure that the people entrusted with working on the machine:

- have noted and understood all the regulations regarding safety,
- are familiar before starting work with all the operating instructions and specifications for the target group relevant for them,
- have easy access always to the technical documentation for this machine,
- and that new personnel before starting work on the machine are familiarised with the safe handling of the machine and its use for its intended purpose, either by verbal instructions from a competent person and/or by means of this technical documentation.

Improper operation can result in personal injuries and material damage. You are responsible for your own safety and that of your employees.

Make sure that no unauthorised person has access to the machine.



CAUTION

Changes to the machine

- Changes to the machine may lead to personal injury.
- **Do not make any change to the machine and use spare parts and accessories that have been approved by Retsch exclusively.**

NOTICE

Changes to the machine

- The conformity declared by Retsch with the European Directives will lose its validity.
- You lose all warranty claims.
- **Do not make any change to the machine and use spare parts and accessories that have been approved by Retsch exclusively.**

1.3 Repairs

This operating manual does not contain any repair instructions. For your own safety, repairs may only be carried out by Retsch GmbH or an authorized representative or by Retsch service engineers.

In that case please inform:

The Retsch representative in your country
Your supplier
Retsch GmbH directly

Your Service Address:

2 Confirmation

This operating manual contains essential instructions for operating and maintaining the device which must be strictly observed. It is essential that they be read by the operator and by the qualified staff responsible for the device before the device is commissioned. This operating manual must be available and accessible at the place of use at all times.

The user of the device herewith confirms to the managing operator (owner) that (s)he has received sufficient instructions about the operation and maintenance of the system. The user has received the operating manual, has read and taken note of its contents and consequently has all the information required for safe operation and is sufficiently familiar with the device.

As the owner/managing operator you should for your own protection have your employees confirm that they have received the instructions about the operation of the machine.

I have read and taken note of the contents of all chapters in this operating manual as well as all safety instructions and warnings.

User

Surname, first name (block letters)

Position in the company

Signature

Service technician or operator

Surname, first name (block letters)

Position in the company

Place, date and signature

3 Packaging, Transport and Installation

3.1 Packaging

The packaging has been adapted to the mode of transport. It complies with the generally applicable packaging guidelines.

NOTICE

Storage of packaging

- In the event of a complaint or return, your warranty claims may be endangered if the packaging is inadequate or the machine has not been secured correctly.
 - **Please keep the packaging for the duration of the warranty period.**
-

3.2 Transport

NOTICE

Transport

- Mechanical or electronic components may be damaged.
 - **The machine may not be knocked, shaken or thrown during transport.**
-

3.3 Temperature fluctuations and condensed water

NOTICE

Temperature fluctuations

The machine may be subject to strong temperature fluctuations during transport (e.g. aircraft transport)

- The resultant condensed water may damage electronic components.
 - **Protect the machine from condensed water.**
-

3.4 Conditions for the Installation Site

Ambient temperature: 5°C to 40°C

NOTICE

Ambient temperature

- Electronic and mechanical components may be damaged and the performance data alter to an unknown extent.
 - **Do not exceed or fall below the permitted temperature range of the machine (5°C to 40°C / ambient temperature).**
-

Atmospheric humidity:

Maximum relative humidity 80% at temperatures up to 31°C, decreasing linearly up to 50% relative humidity at 40°C

*NOTICE***Atmospheric humidity**

- Electronic and mechanical components may be damaged and the performance data alter to an unknown extent.
 - **Do not exceed the admissible range for atmospheric humidity.**
-

3.5 Electrical Connection **WARNING**

When connecting the power cable to the mains supply, use an external fuse that complies with the regulations applicable to the place of installation .

- Please check the type plate for details on the necessary voltage and frequency for the device.
 - Make sure the levels agree with the existing mains power supply.
 - Use the supplied connection cable to connect the device to the mains power supply.
-

*NOTICE***Electrical connection**

- Mechanical or electronic components may be damaged.
 - **Please observe the information on the type plate.**
-

3.6 Type Plate Description

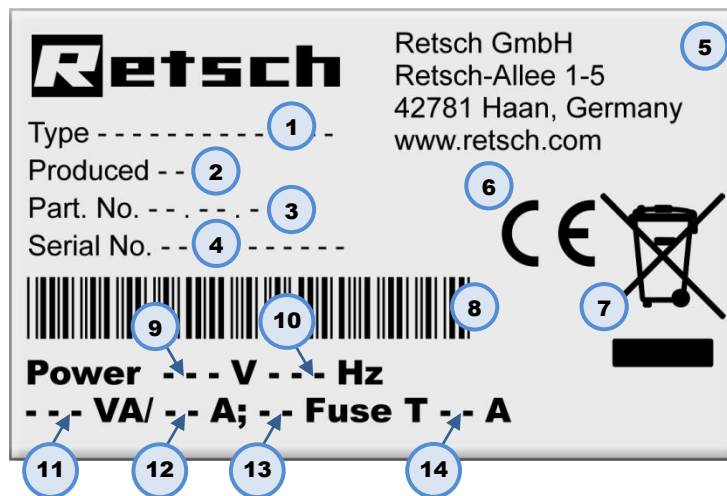

Fig. 1: Type plate lettering

- 1 Device designation
- 2 Year of production
- 3 Part number
- 4 Serial number
- 5 Manufacturer's address
- 6 CE marking
- 7 Disposal label
- 8 Bar code
- 9 Power version
- 10 Mains frequency
- 11 Capacity
- 12 Amperage
- 13 Number of fuses
- 14 Fuse type and fuse strength

In the case of questions please provide the device designation (1) or the part number (3) and the serial number (4) of the device.

3.7 Removing the Transportation Aid

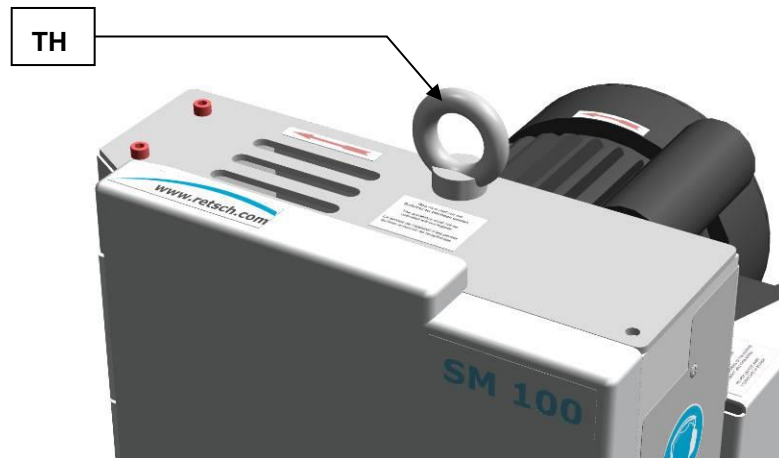

Fig. 2: Removing the transport aid

Only use the transport aid (TH) when lifting the device. The device weighs approx. 73 kg. Select secure lifting equipment that is approved for this weight. Keep the eyebolt (TH) for transportation at a later date. The eyebolt must be removed before assembling the hopper.

3.8 Frame assembly

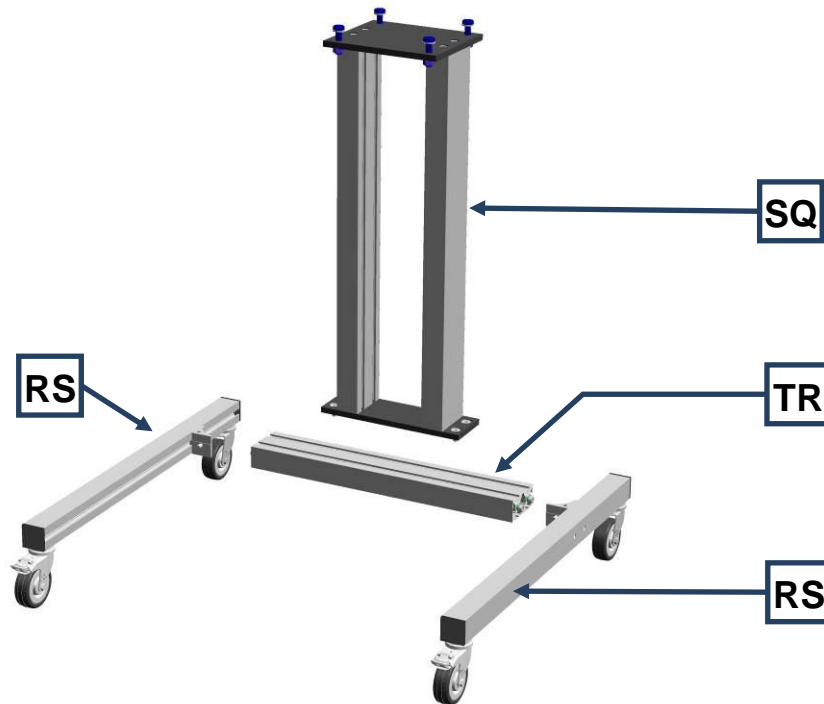

Fig. 3: Components of the stand

The components come pre-assembled to simplify assembly of the frame.

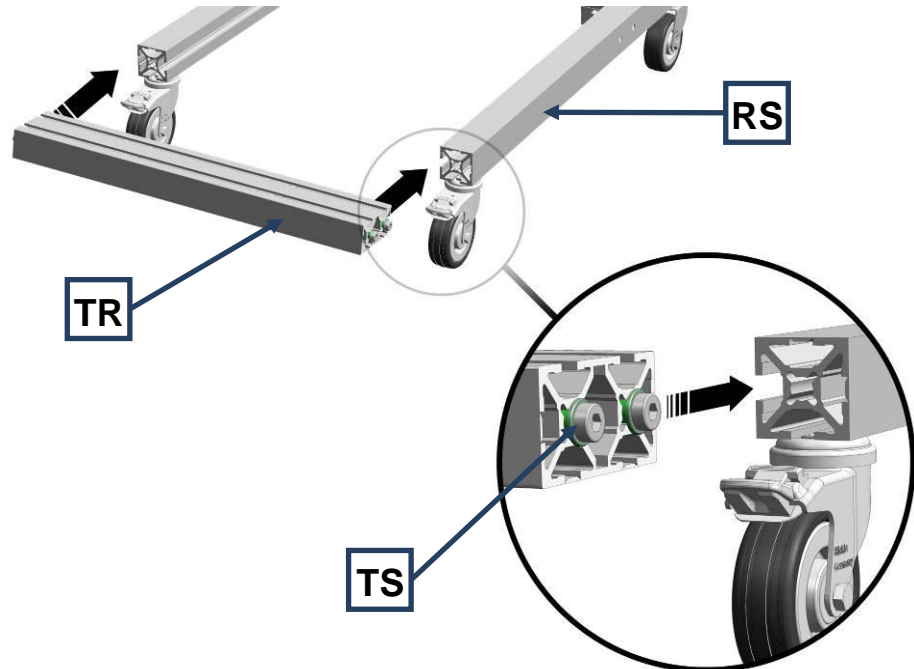

Fig. 4: Assembling the crossbar

- Where necessary slightly loosen the four screws (**TS**) on the crossbar (**TR**).
- Slide the crossbar into the lateral guides of the left and right roller track (**RS**).

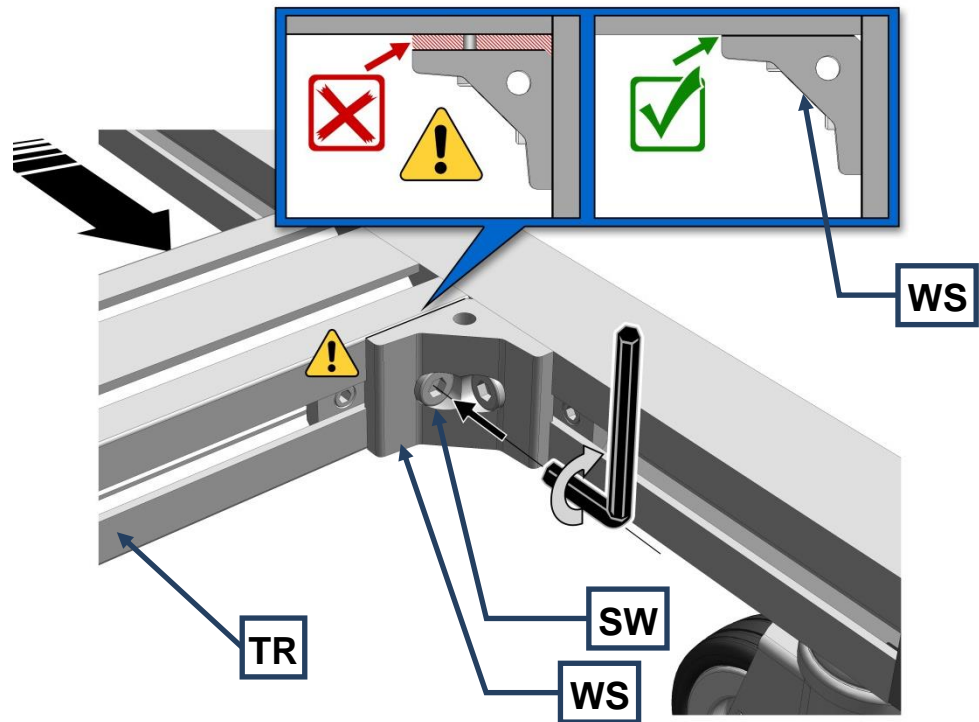

Fig. 5: Fastening the crossbar angle bracket

NOTICE

Ensure that the crossbar (**TR**) is aligned flush with the pre-assembled angle section (**WS**). Tighten the screw on the left and right of the angle section (**SW**).

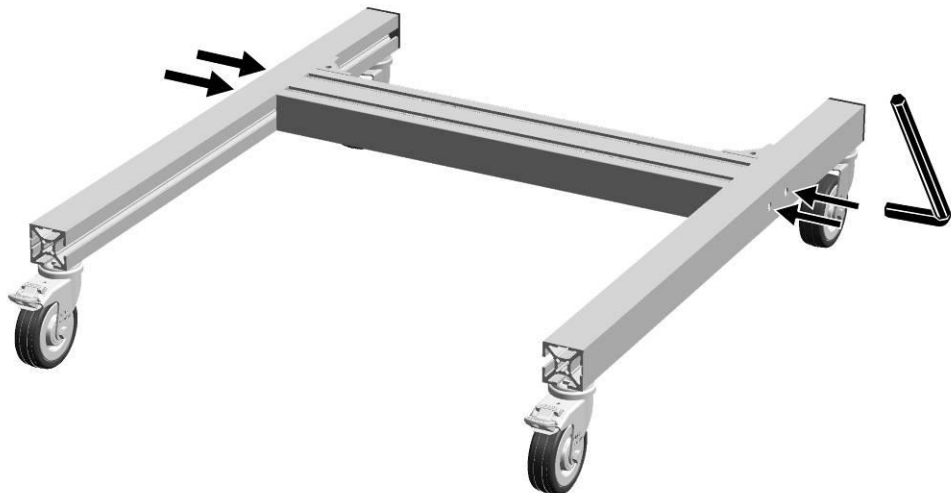

Fig. 6: Screwing the crossbar tight

- Tighten the four Allen screws.

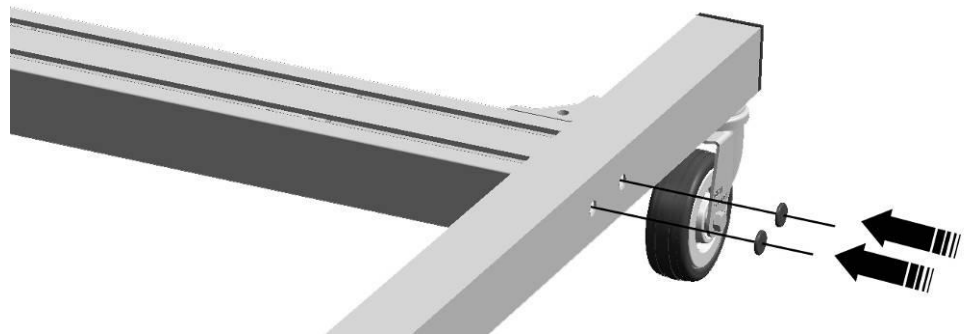

Fig. 7: Mounting the side protective caps

- Place the four black plastic caps on the openings.

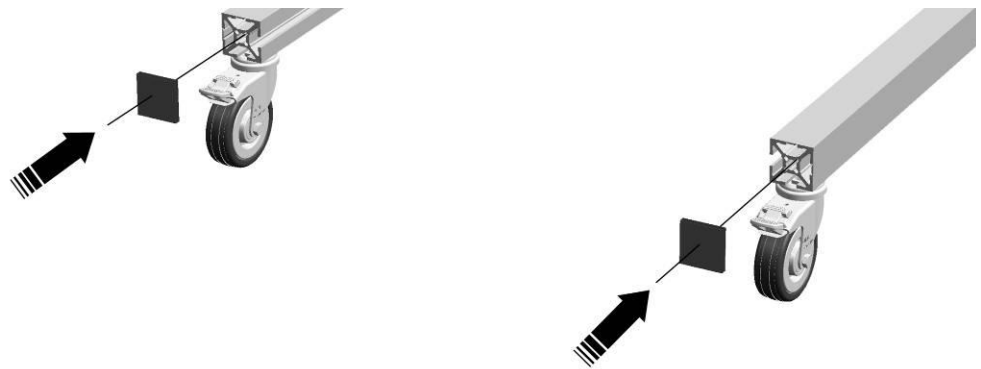

Fig. 8: Mounting the front protective caps

- Place the two caps on the ends of the roller track.

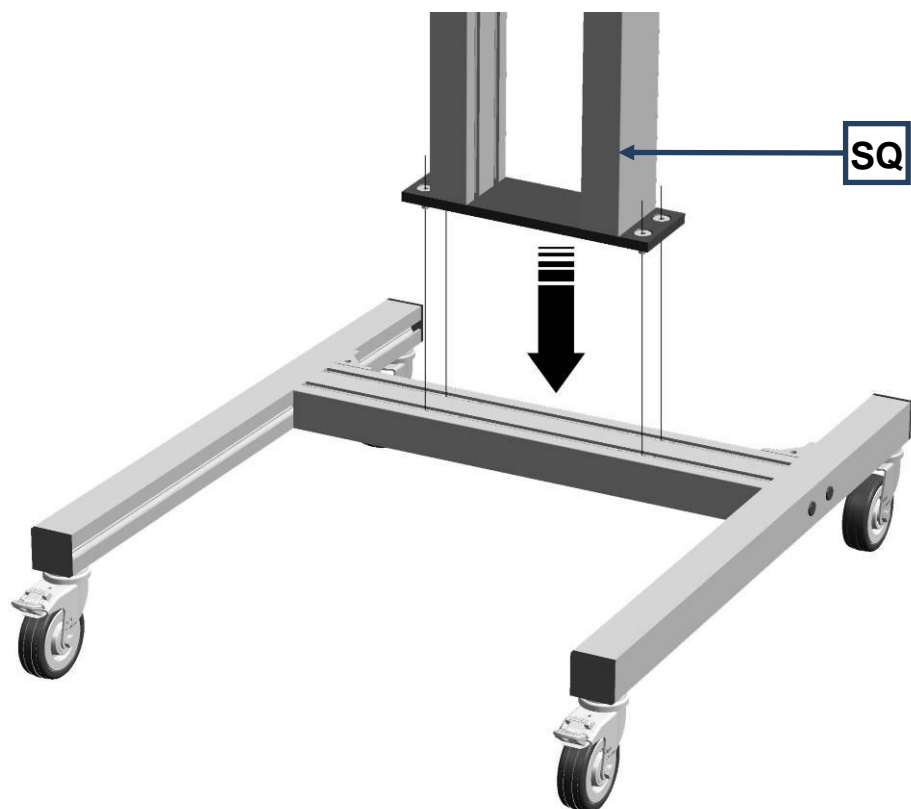

Fig. 9: Placing the crossbar on the stand

- Place the stand (SQ) on the crossbar.

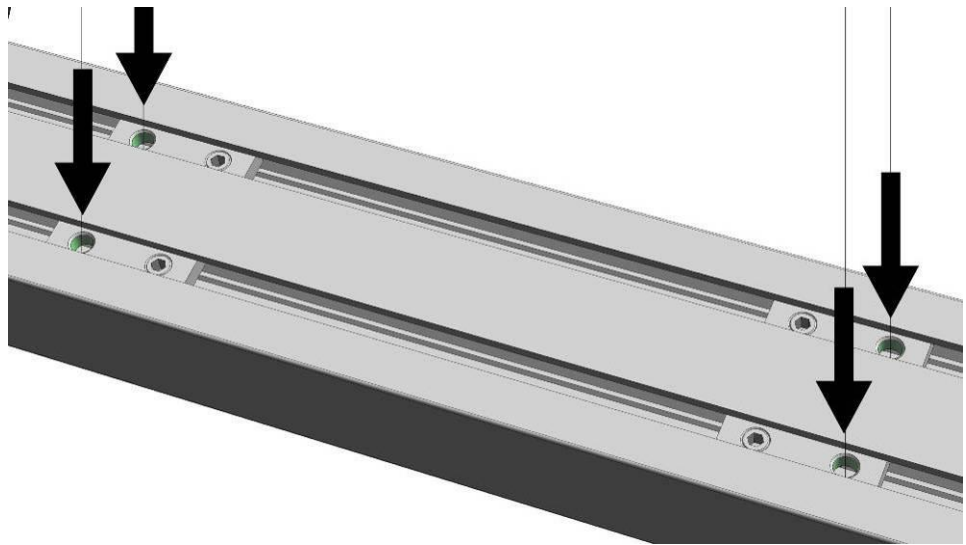

Fig. 10: Points for securing the stand

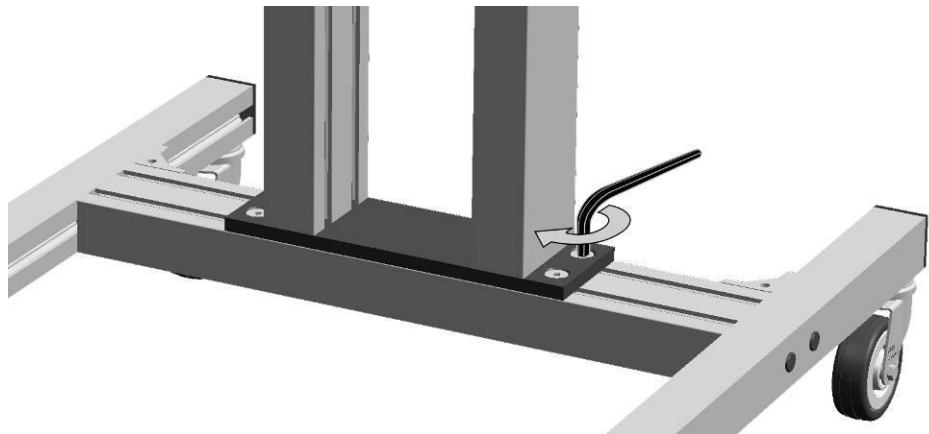

Fig. 11: Screwing the stand onto the crossbar

- Screw the stand (SQ) onto the crossbar.

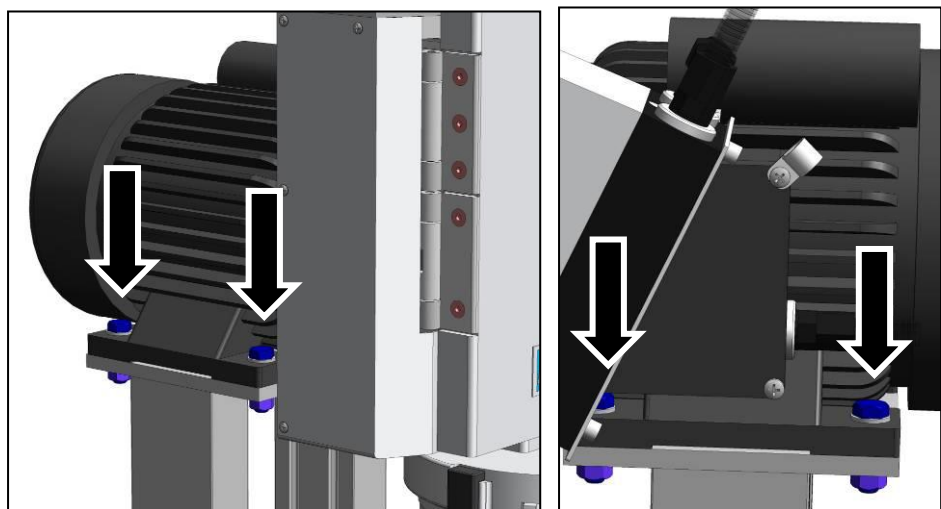

Fig. 12: Assembling the SM 100

- Then place the SM100 on the base frame.
- Using the 4 screws, screw the SM100 housing tightly onto the base frame.

3.9 Mounting the Feed Hopper

WARNING

1.W0004

Risk of injury to skin and hands

Fast rotating cutting blade

- There is a risk of injuring hands, fingers and skin.
- **Never operate the device without a feed hopper.**

NOTICE

Transport safeguard

- Components may be damaged.
- **Operate the machine only without the transport safeguard or transport the machine only with transport safeguard.**

3.9.1 Removing the Transport Safeguard

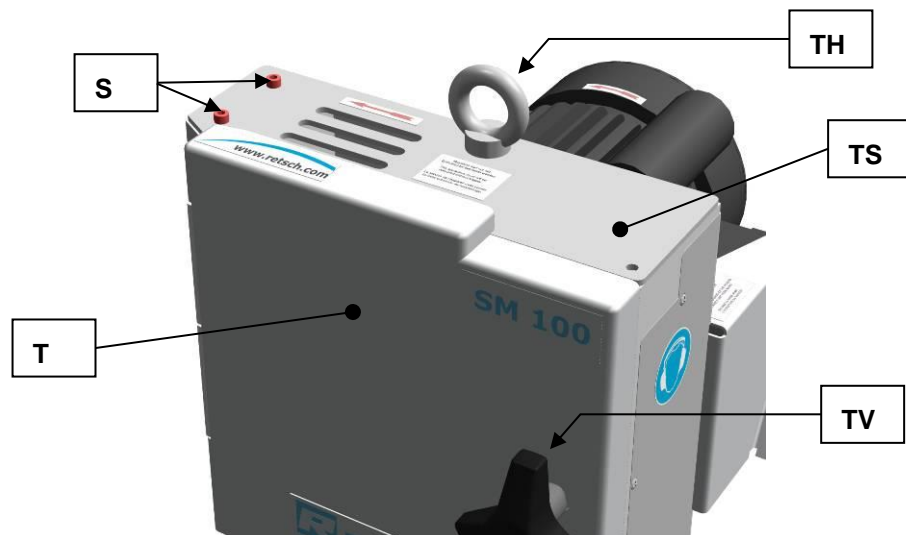

Fig. 13: Removing the transport lock

- Remove the transport aid (TH).
- Turn the door lock grip (TV) until the door can be opened.
- Open the grinding area door (T).
- Remove the two safety screws (S).

NOTICE

Retain the transport lock (TS) for transportation at a later date.

3.9.2 Mounting the Feed Hopper

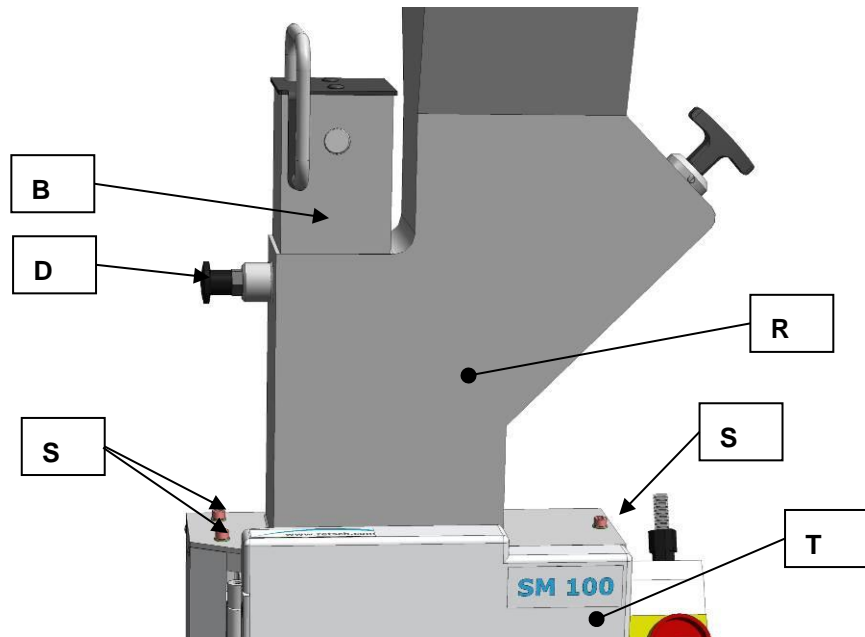

Fig. 14: Mounting the feed hopper

- Open the grinding area door (T).
- Pull the plunger (B) so it engages in the uppermost position.
- Place the feed hopper (R) on the device (see diagram)

CAUTION

It is possible for the feed hopper (R) to fall from the device as long as it is not secured by the three socket screws.

- Unlock the locking pins (D) of the plunger (B).
- Slide the plunger down.
- Screw in the three supplied socket screws (S).
- Initially only tighten the screws loosely.
- Close the grinding area door (T).
- Twist the rotary grip of the grinding area door.
- Align the feed hopper so that the plunger can be easily moved up and down without tilting.
- Screw the three socket screws tight (10Nm).
- Check again that the plunger can be easily moved up and down without tilting.

NOTICE

The grinding area door and the grip of the door lock are somewhat stiff when new.

3.10 Installation of the Device

Installation height: maximum 2000 m above sea level

NOTICE

Installation

- Depending on the operating status of the mill, there may be slight vibrations.
- **Place the mill on an even, flat and balanced supporting surface only. The supporting surface must be stable and must not vibrate.**

NOTICE

Installation of the machine

- It must be possible to disconnect the machine from the mains at any time.
- **Install the machine such that the connection for the mains cable is easily accessible.**

3.11 Height adjustment and alignment of the support structure



WARNING

Risk of injury caused by the machine overturning

Inadmissible height adjustment of the support structure

- When adjusting the support structure, the machine can fall over and cause injuries if the set screw has been unscrewed too far.
- **Always use an SW17 open end wrench when adjusting the height.**
- **Only raise the support structure so far that no more than 20 mm of the set screw (H4) can be seen between the top nut (H2) and the bottom nut (H3).**
- **Ensure that the machine is in a secure position.**

NOTICE

H0011

Damage to the machine caused by the machine overturning

Inadmissible height adjustment of the support structure

- When adjusting the support structure, the machine can fall over and be damaged if the set screw has been unscrewed too far.
- **Use an SW17 open end wrench when adjusting the height.**
- **Only raise the support structure so far that no more than 20 mm of the set screw (H4) can be seen between the top nut (H2) and the bottom nut (H3).**
- **Ensure that the machine is in a secure position.**

The height of two wheels on the support structure can be changed to compensate for an uneven surface and for the optimal alignment of the machine.

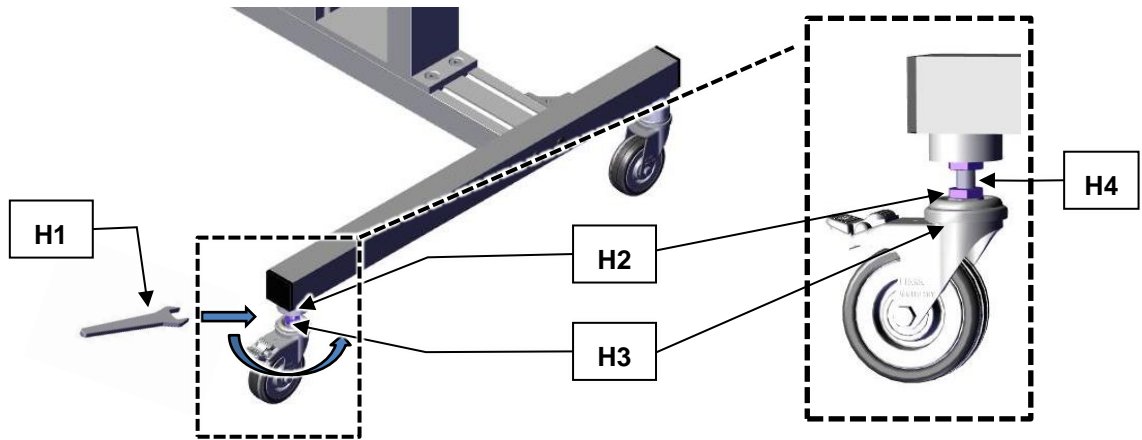

Fig. 15: Adjusting the height of the support structure

Fig. 16:
Adjusting the height of the support structure (detail)

No.	Designation
H1	SW17 open end wrench
H2	Top nut
H3	Bottom nut
H4	Set screw

Proceed as follows to adjust the height of the support structure:

- Using an SW17 open end wrench (**H1**), loosen the top nut (**H2**).
 - Twist the bottom nut (**H3**) to adjust the height of the support structure. Take care that no more than 20 mm of the set screw (**H4**) can be seen.
 - Secure the height of the support structure by tightening the top nut (**H2**) using the SW17 open end wrench (**H1**).
 - Repeat the process with the other wheel until the support structure has been aligned almost horizontally.
- ⓘ When aligning the support structure, a backwards tilt of approx. 1-2° is recommended for an ideal operating function.
- ⓘ We recommend using a spirit level to check the ideal incline of the support structure.

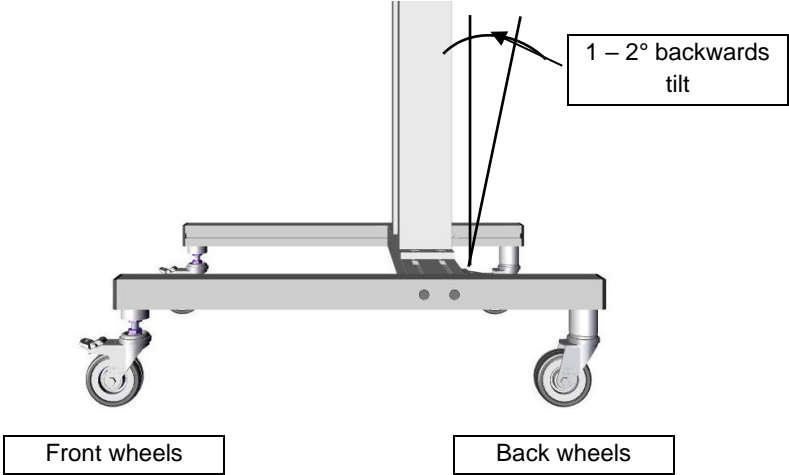

Fig. 16: Optimal alignment

4 Technical Data

4.1 Use of the Device for the Intended Purpose

Target group: Operating companies, operators

Designation of machine model: SM 100

This powerful cutting mill is used to grind elastic and fibrous products and product mixtures in batches or continuously. In addition this device is fundamentally not designed to grind wet or damp materials. The special moulding of the cutting tools in conjunction with the drive produces fast, efficient grinding without the ground material interrupting the procedure.

With the following special features

The new powerful grinding mill can successfully perform difficult grinding tasks where other grinding mills fail. The device facilitates particularly effective preliminary grinding of heterogeneous material mixtures such as waste or electronic components. Analytical fineness can usually be achieved in one step. The cutting mill can also be used successfully with a number of other materials. The grinding material is only slightly warmed in the process so that the mill can also be used for materials that are temperature sensitive.

Use with the large selection of sieves, hoppers and collecting vessels enables the equipment to be adjusted to individual tasks.

- Fast, successive grinding by 18 spiral-shaped cutting plates distributed round the rotor
- Parallel section rotor
- Cutting tools made from quality materials
- User-friendly with central locking and control panel
- Consistent reliability of all operational device components
- Diverse use possible due to device variations and wide range of accessories
- Powerful grinding thanks to 1,5 kW motor with high torque
- Can be cleaned very quickly due to the push-fit rotor
- Defined ultimate fineness through bottom sieves with mesh sizes of 0.25 - 20 mm

NOTICE

Area of use of the machine

- This machine is a laboratory machine designed for 8-hour single-shift operation.
 - **This machine may not be used as a production machine nor is it intended for continuous operation.**
-

4.2 Emissions

 **CAUTION****Damage to hearing**

The level of noise can be high depending on the type of material, the knife used, the speed set and the duration of the grinding process.

- Noise that is excessive in terms of level and duration can cause impaired or permanently damaged hearing.

- **Ensure suitable sound-proofing measures or wear hearing protection.**



Noise emissions in accordance with DIN 45635-31-01-KL3.

Emissions at 1m distance:

– approx. 68 dB (A) when idling

When grinding depending on the material to be ground:

– approx. 85 to 95 dB (A) with peaks up to 110 dB (A)

4.3 Degree of Protection

IP54

4.4 Motor rotation speed

The motor speed is 1500 min⁻¹.

4.5 Receptacle Volume

The capacity is < 5 l and can be expanded to up to 26 l using accessories.

4.6 Rated Power

1500 W

4.7 Dimensions and Weight

Height:	1675 mm
Width:	582 mm
Depth:	700 mm
Weight:	approx. 73 kg (without hopper, rotor and base frame)

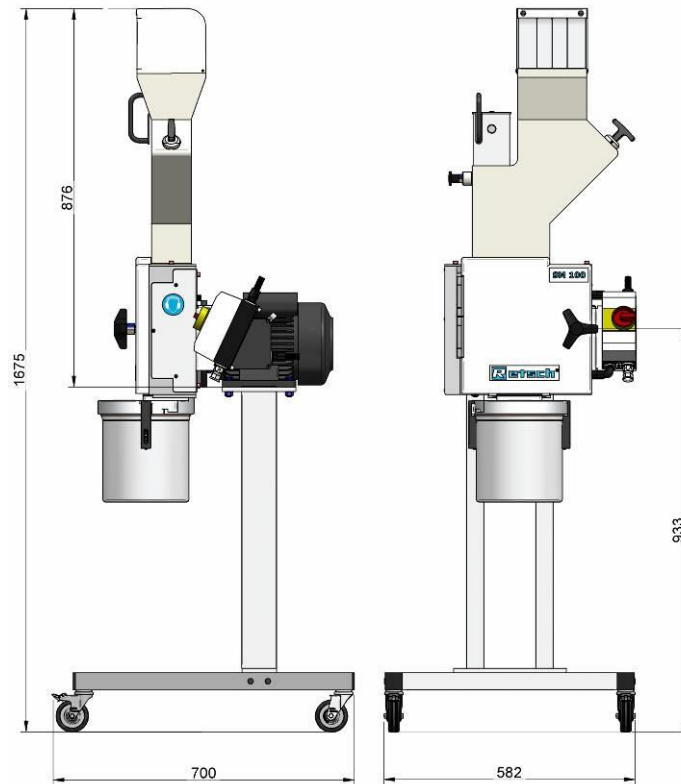

Fig. 17: Dimensions

4.8 Required Floor Space

1090 mm x 765 mm – no safety distances necessary

4.9 Note on the motor

NOTE The rotary control on the motor has no function with the SM 100 (1~ 200–240 V 50/60 Hz).



Fig. 18: Rotary control on the motor

5 Operating the Device

5.1 Views of the Instrument

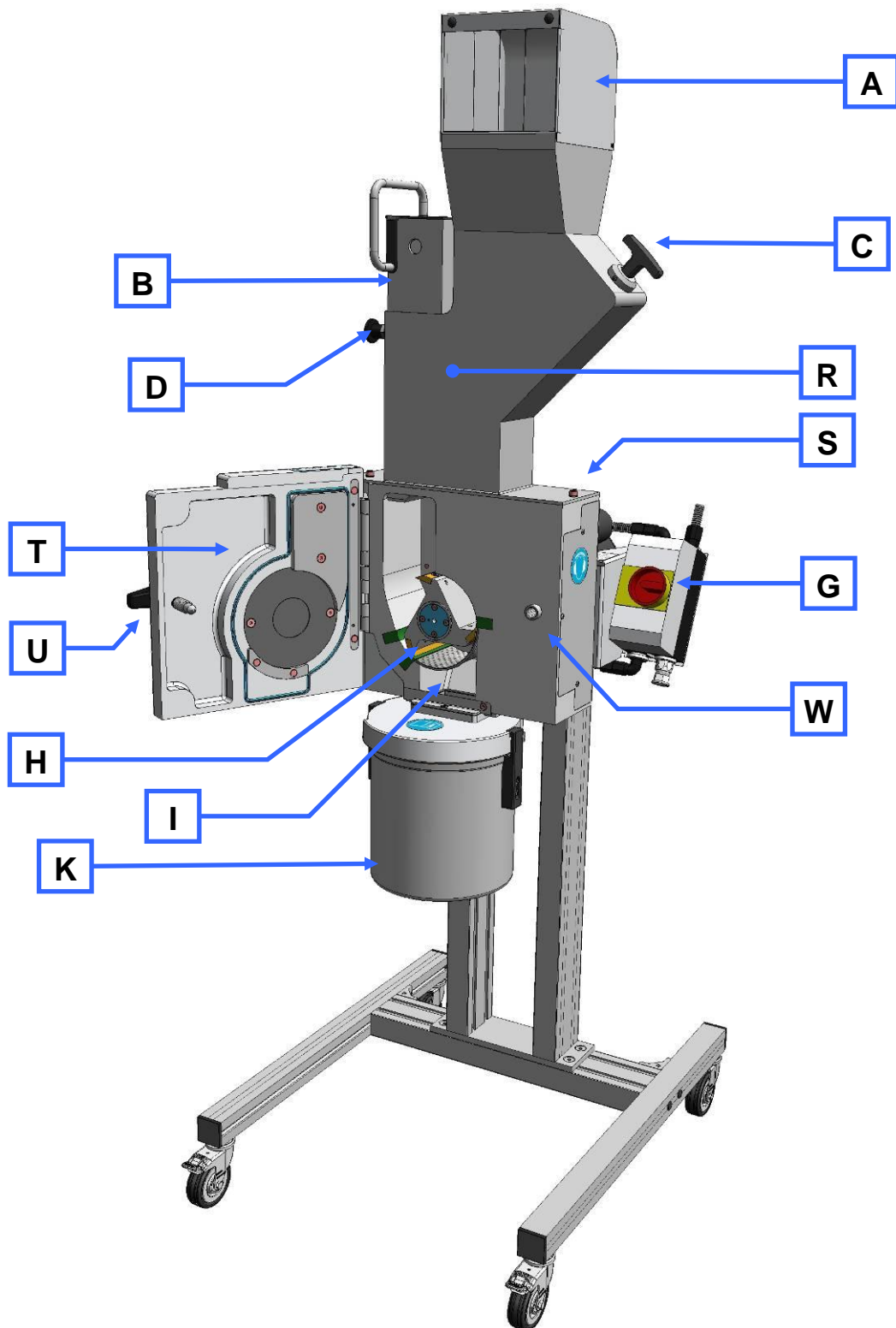

Fig. 19: Front view

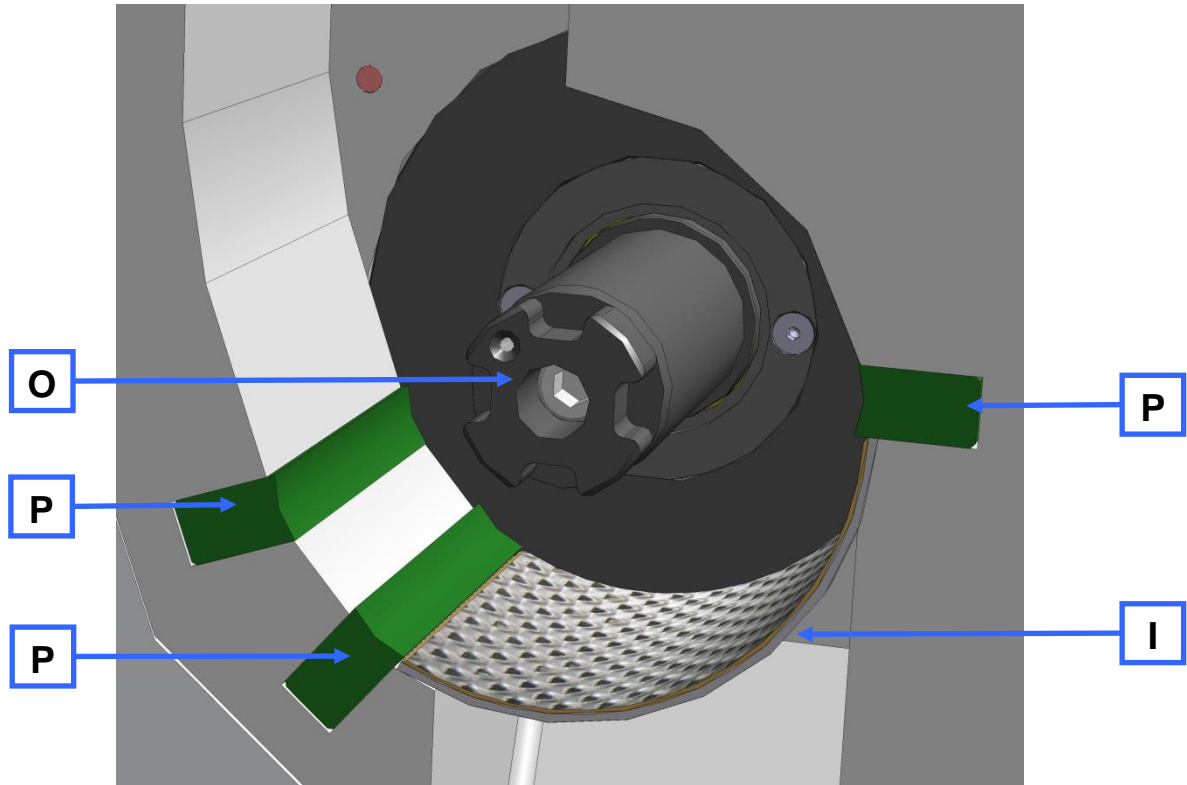

Fig. 20: Grinding area view

5.2 Overview table of the parts of the device

Element	Description	Function
A	Safety guard for the feed hopper	Prevents contact with the feed hopper
B	Plunger	Releases the material feed chute in pulled state. Pushes grinding material onto the rotor.
C	Metering plunger	Pushes the grinding material into the feed chute area of the fill plunger <ul style="list-style-type: none"> – Extended: grinding material can be loaded. – Inserted: grinding material remains in the area of the fill plunger.
D	Locking pin	Prevents, blocks or releases the fill plunger. <ul style="list-style-type: none"> – Extended: free movement of the fill plunger is possible – Released: fill plunger engages in the uppermost position
G	On/off switch	Starts and stops the device
H	Parallel section rotor	Grinding tool
I	Bottom sieve	Influences the ultimate fineness of the grinding material through the size and type of perforation
J	Ring filter	Air outlet and filter for material to be ground
K	Collecting receiver	Collects ground material
O	Rotor shaft	Accommodates the grinding tool
P	Cutting bars	Counterpart to grinding tool
R	Feed hopper	Feeding the grinding material
S	Feed hopper fixing screws	Safety bolts for the feed hopper
T	Grinding Chamber door	Closes the grinding area
U	Threaded handle	Closes the grinding area door

5.3 Opening and Closing of the Device

CAUTION

V0063

Possibility of personal injuries

Injuries due to rotating rotor

- Reaching into the turning rotor
- **Never open the grinding chamber door while the rotor or the motor is still rotating.**



- Stop the device by actuating the switch (G).
- Open the grinding area door by turning the handle (U).

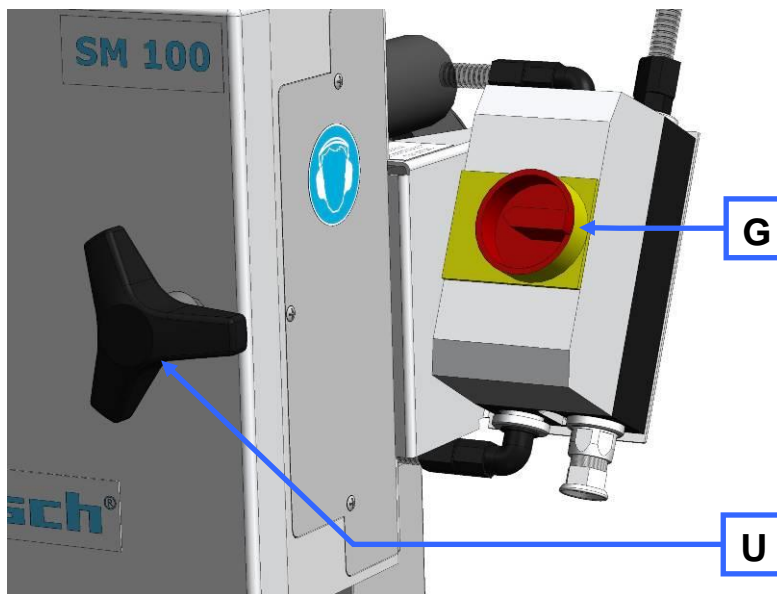

Fig. 21: Opening the grinding area door

5.4 Mounting the bottom sieve

- Select the appropriate bottom sieve.
- Open the mill housing and slide the bottom sieve (I) of your choice into the device.

5.5 Replacing the rotor

CAUTION

Injuries in the form of cuts

Sharp cutting edges on the rotors and cutting bars

- The sharp cutting edges on the rotors and cutting bars can injure hands.
- **Wear protective gloves when replacing the cutting rotors and cleaning the grinding chamber.**
- **Use the rotor extraction tool when handling the cutting rotors.**

NOTICE

Wear or damage of the device

Operation without grinding set

- During operation of the device without grinding set, excessive wear or damage to the device may occur.
- **Operate the device only with a grinding set mounted.**

NOTICE

Damage to mechanical components

Blockages typical of cutting mills

- When coarse, solid material is fed in for grinding, the high feeding capacity of the standard rotor can cause blockages that are typical of the cutting mills.
- **If blockages occur, switch off the mill immediately and remove the clogging material.**

5.5.1 Removing the Rotor

- Stop the device.
- Open the grinding area door.
- Screw the removal grip (EG) on the rotor and pull the rotor from the drive shaft.

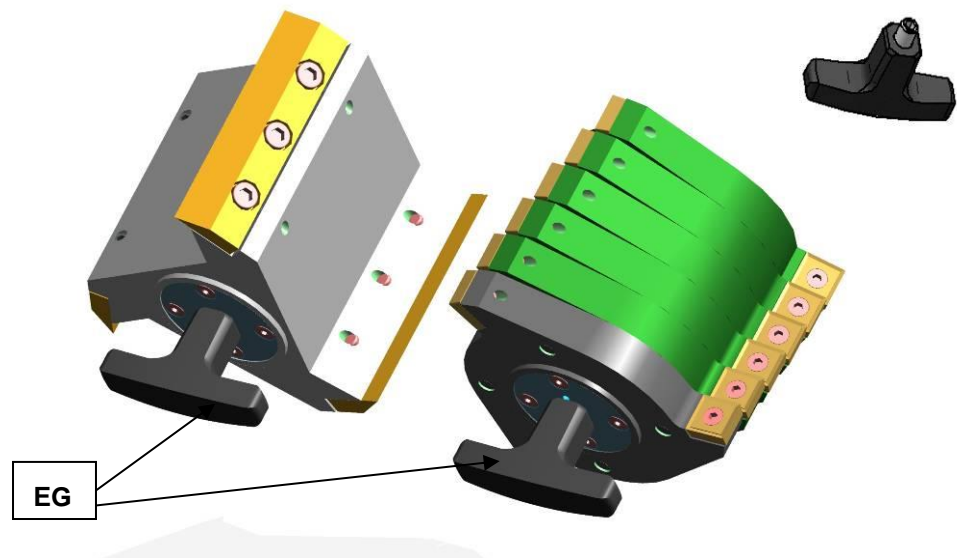

Fig. 22: Removal grip

5.5.2 Inserting the Rotor

- Clean and lubricate the motor shaft and the rotor.
- Slide the rotor onto the motor shaft.

Apart from this the device is largely maintenance-free.

Nevertheless we recommend that the cutting tools are checked at least once a month depending on the frequency of use.

5.6 Inserting the filter unit and collecting receptacle

The filter unit serves as air outlet for the flow of air generated by the grinding rotors.

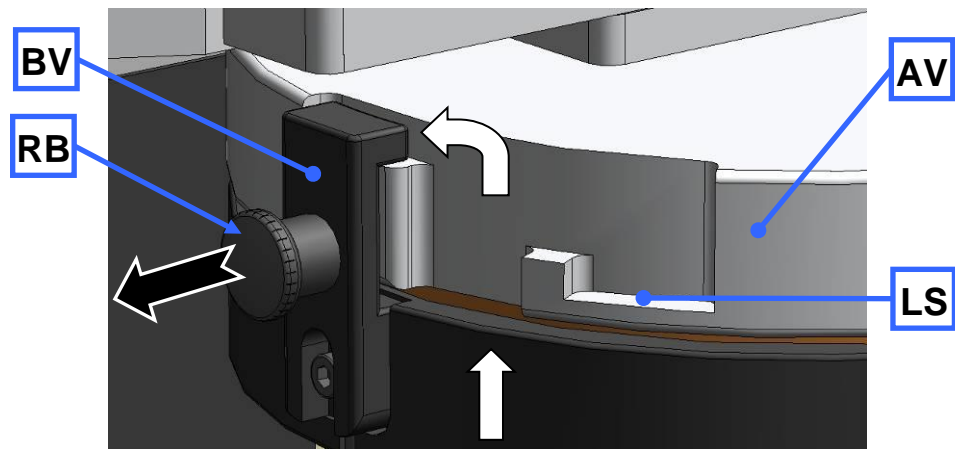

Fig. 23: Attaching and removing the filter unit

- Insert the bayonet lock (BV) on the filter unit (J) into the discharge flange (AV) as shown in the diagram.
- Twist the filter unit in a clockwise direction to engage the bayonet lock.
- To remove the filter unit, pull the locking pins (RB) out to release the bayonet lock (BV).

Alternatively the collecting receiver can be placed directly on the discharge flange. The discharge of the air flow is prevented in the latching position (BV).

In the latching position (LS) a gap remains between the discharge flange and collecting vessel; this permits air discharge.

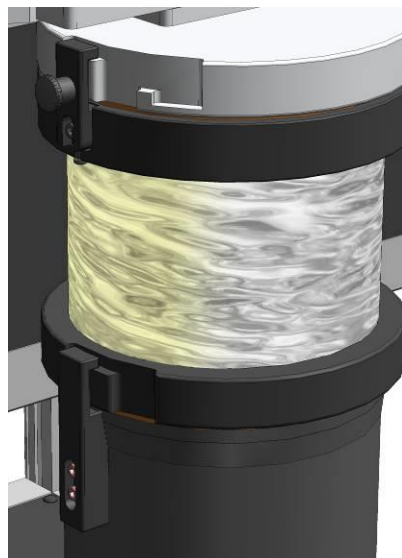

Fig. 24: Collecting receiver and filter unit

5.7 Switching On and Off

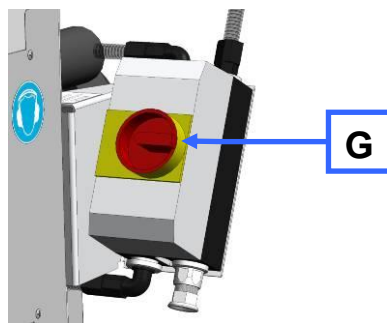

Fig. 25: On/off switch

You can switch the device on/off using the on/off switch (**G**). The motor starts up or is shut down when the switch is actuated. The switch disconnects the device from the mains.

5.8 Starting the grinding process

NOTICE

Only fill test material when the device is running because this may otherwise lead to motor blockages when starting the device.

The cutting gap between the rotor and cutting bar must be checked after each grinding operation with hard materials. The maximum cutting gap may be 0.5 mm (minimum is 0.3 mm). (See chapter on *Adjusting the cutting bars*)

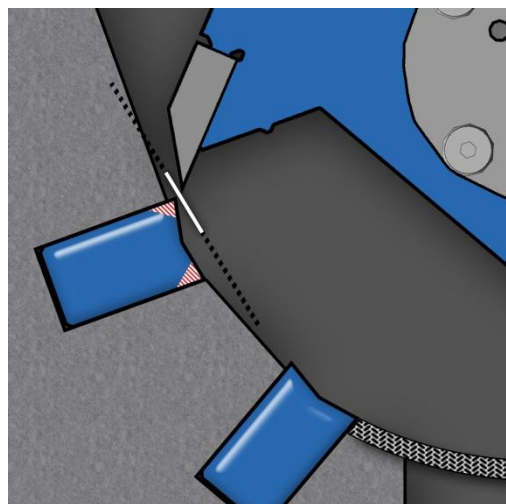

Fig. 26: Cutting gap

5.9 Stopping the grinding process

The grinding process in progress can be stopped by actuating the on/off switch. The grinding area door can now be opened.

6 Cleaning and service

6.1 Adjusting the cutting bars

The cutting gap must be checked to ensure that the device is functioning satisfactorily (target distance 0.3mm). For this reason the cutting bars (**SL**) are arranged so that they can be shifted to permit adjustments to the cutting gap.

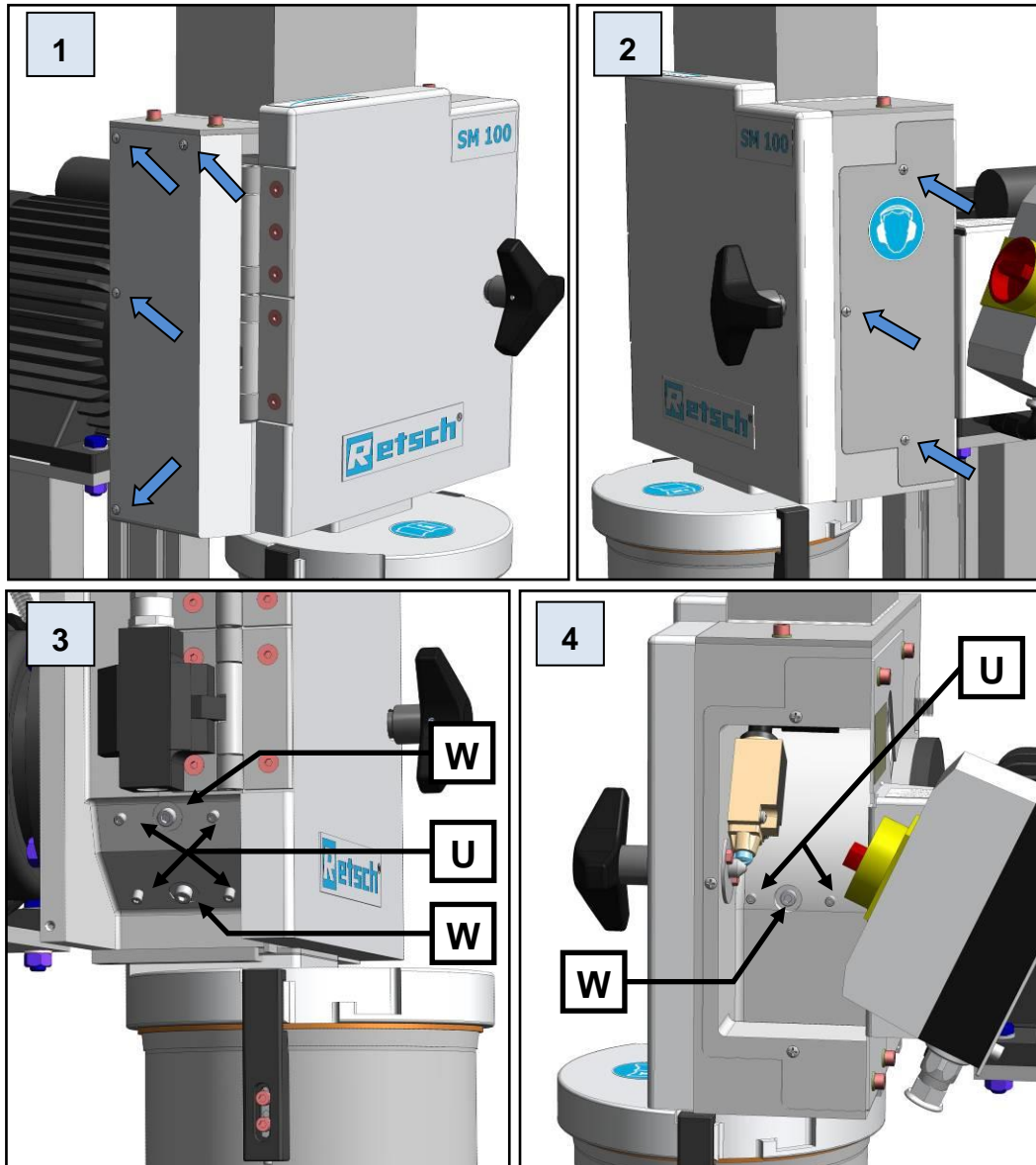

Fig. 27: Access to the cutting bars

- Unscrew the four screws on the left-hand cover [1].
- Unscrew the three screws on the right-hand cover [2].
- Open the grinding area door.
- Pull the rotor approx. 10 mm out of the grinding area until it can be freely rotated.

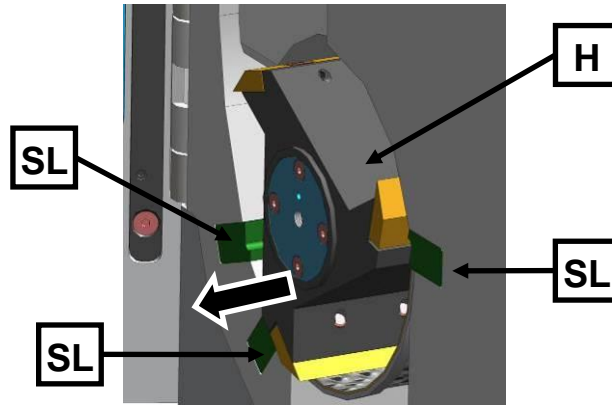

Fig. 28: Freely rotate the rotor

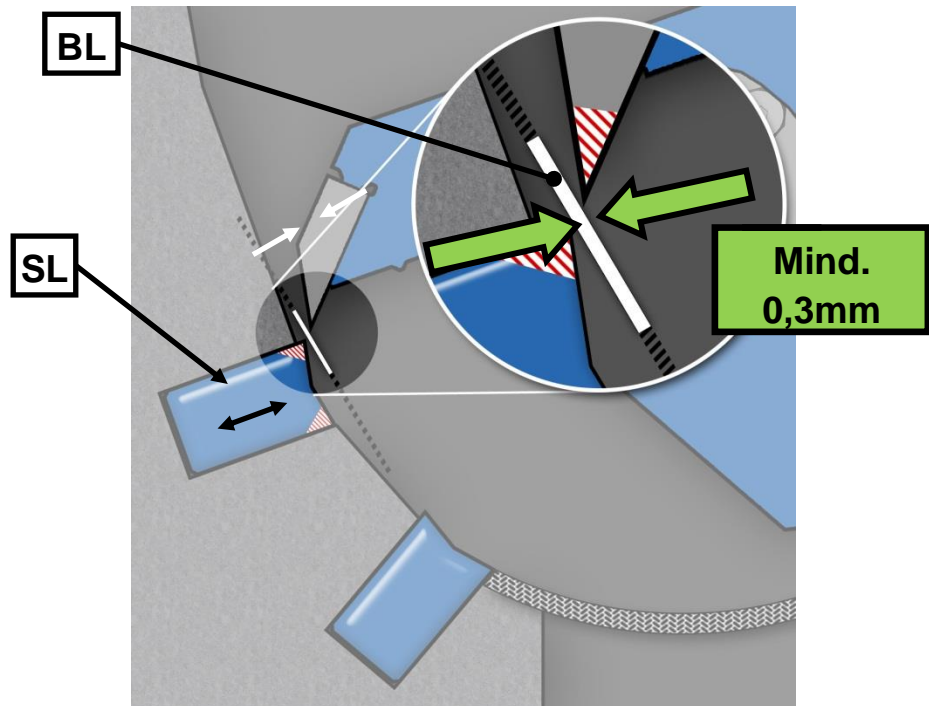

Fig. 29: Adjust the cutting gaps

- Using a feeler gauge (**BL**) check the cutting gap for all three cutting bars (**SL**). It should be at least 0.3 mm.

The feeler gauge (**BL**) must be placed as shown in the diagram. The cutting gap must show a uniform distance across its entire depth. For this reason check the cutting gap across its entire depth.

The cutting edge that has the smallest distance to the knife denotes the cutting gap (**SP1**). The second cutting edge can have a larger cutting gap width.

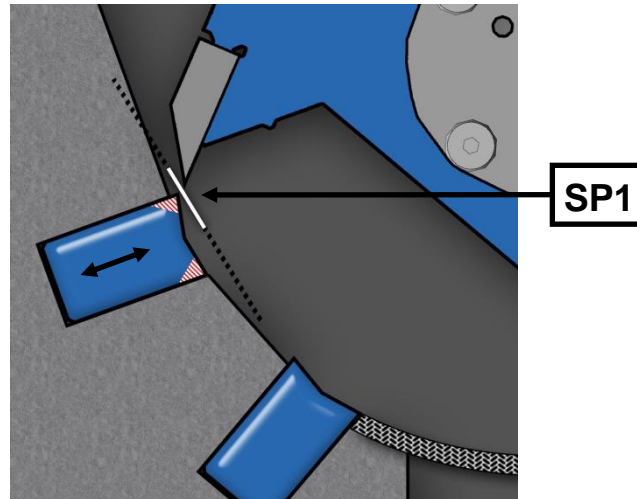

Fig. 30: Cutting gap

- By twisting the stud bolts (**U**) to the right, slide the cutting bar closer to the rotor blade and thereby reduce the cutting gap. Increase the cutting gap by twisting to the left [3].
- Tighten the screw (**WS**) and check the cutting gap. Repeat the process if necessary.
- After adjusting the cutting bar, tighten the screw (**W**) firmly again to 7Nm [4].
- Finally re-assemble the right and left-hand cover on the device.

NOTICE

Do not set the cutting gap to less than 0.3 mm. Contact between the cutting plates and cutting bars can damage the mechanical components.

The tightening torque of the screw (**W**) must be 7Nm. This is necessary to guarantee that the cutting bars are securely positioned.

6.2 Cleaning

CAUTION

Injuries in the form of cuts

Sharp cutting edges on the rotors and cutting bars

- The sharp cutting edges on the rotors and cutting bars can injure hands.
- **Wear protective gloves when replacing the cutting rotors and cleaning the grinding chamber.**
- **Use the rotor extraction tool when handling the cutting rotors.**

CAUTION

Cuts

Danger due to shears on the bottom sieve

- There is risk of cuts from the shears when inserting and removing the bottom sieve.
- **Do not put hands in the outlet hopper.**
- **Only change or remove the sieve when the rotor has been removed.**

V0055

⚠ WARNING

1.W0004

Risk of injury

When device is not correctly assembled after cleaning

- There is a risk of injury to the operator.
- **The device may only be cleaned by skilled personnel who have been sufficiently instructed in operating the device.**

The following components on this device can be removed or moved for cleaning purposes:

- Lift up the feed hopper safety guard
- Remove the feed hopper
- Remove the rotor
- Remove the sieve
- Remove the collecting receiver
- Remove the outlet flange

6.2.1 Clean the feed hopper

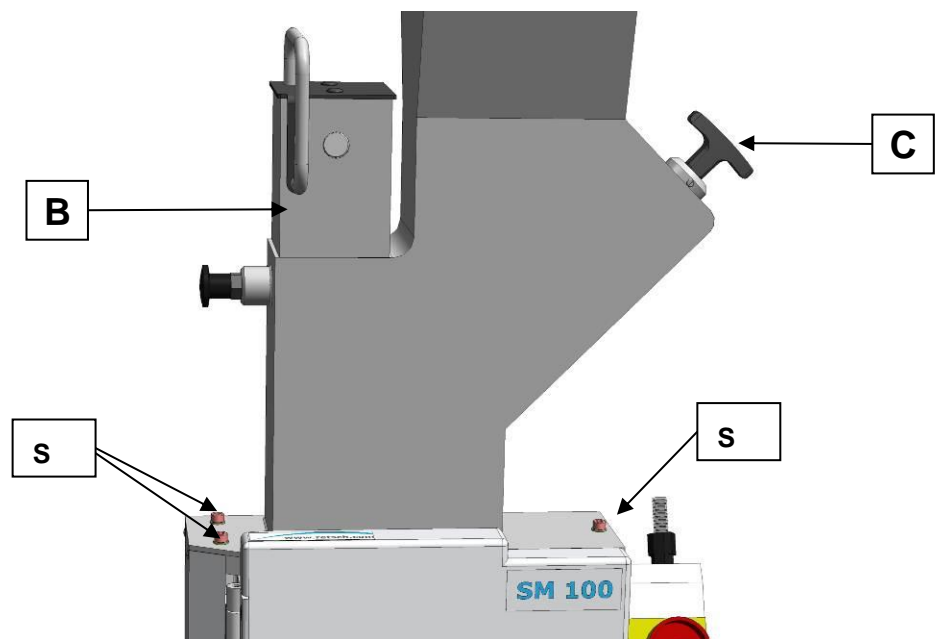

Fig. 31: Removing the feed hopper

Normally it is sufficient to clean the feed hopper through the fill shaft.

- To do this pull out the plunger (B) and the metering plunger (C).

6.2.1.1 Lift up the feed hopper safety guard

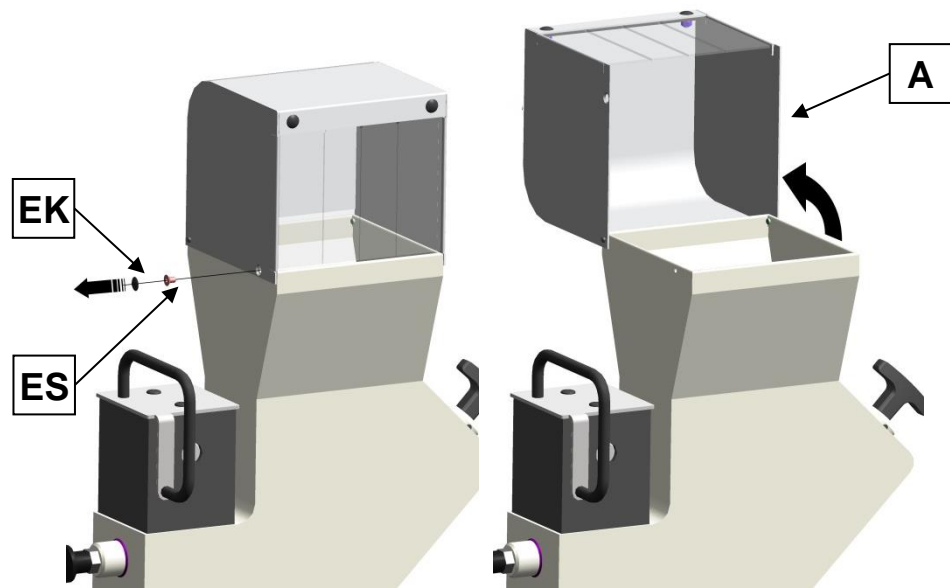

Fig. 32: Lifting up the feed hopper safety guard

- Remove the cap cover (**EK**).
- Loosen the screw (**ES**) on the feed hopper safety guard.
- Lift up the feed hopper safety guard (**A**).

If the feed hopper needs more thorough cleaning it can also be dismantled for cleaning.

6.2.1.2 Remove the feed hopper

⚠ WARNING

W0004

Risk of injury to skin and hands

Fast rotating blades

- There is a risk of injury to hands, fingers and skin.
- **Never operate the device without the feed hopper.**

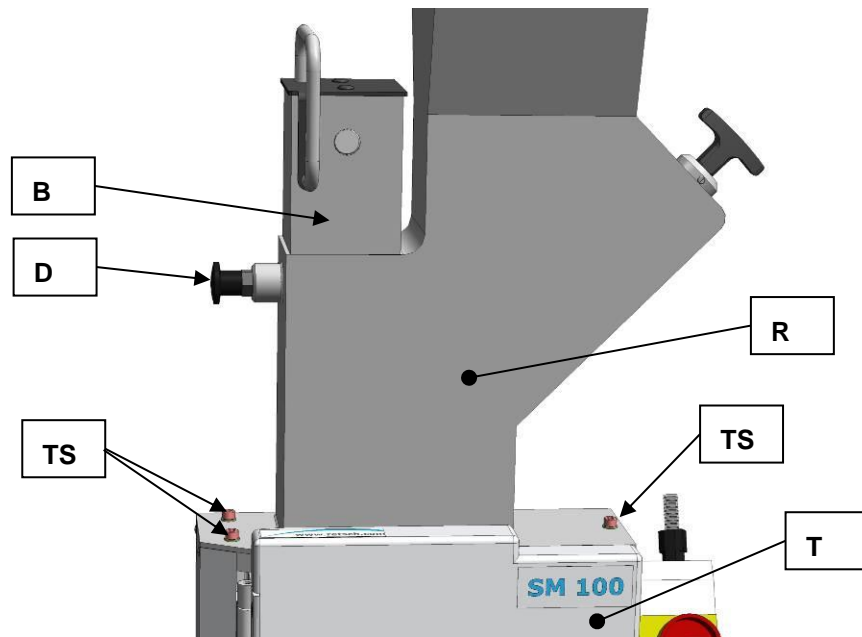

Fig. 33: Mounting the feed hopper

- Disconnect the device from the mains by pulling the plug from the socket.
- Open the grinding area door (T).
- Unscrew the three screws (TS).
- Lift the feed hopper out of the device for cleaning.

Follow the instructions in the following section to mount the feed hopper.

6.2.1.3 Mount the feed hopper

- Open the grinding area door (T).
- Place the feed hopper (R) on the device (see diagram).

⚠ CAUTION

It is possible for the feed hopper (R) to fall from the device as long as it is not secured by the two socket screws.

- Screw in the two socket screws supplied(S).
- Initially only tighten the screws loosely.
- Close the grinding area door (T).
- Twist the rotary grip of the grinding area door.
- Align the feed hopper so that the plunger can be easily moved up and down without tilting.
- Screw the three socket screws tight (10Nm).
- Check again that the plunger can be easily moved up and down without tilting.

6.2.2 Clean grinding area

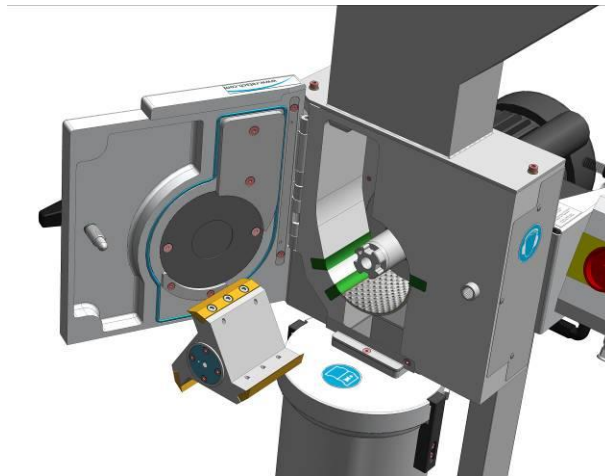

Fig. 34: Removing the rotor

- Open the grinding area door (T).
- Pull the plunger (B) into the uppermost latching position.
- Screw the removal grip (EG) onto the rotor and pull the rotor from the drive shaft.
- Remove the sieve.

6.2.3 Remove the discharge flange

WARNING

2.W0004

Risk of injury to skin and hands

Fast rotating blades

- There is a risk of injury to hands, fingers and skin.
- **Never operate the device without the discharge flange**
-

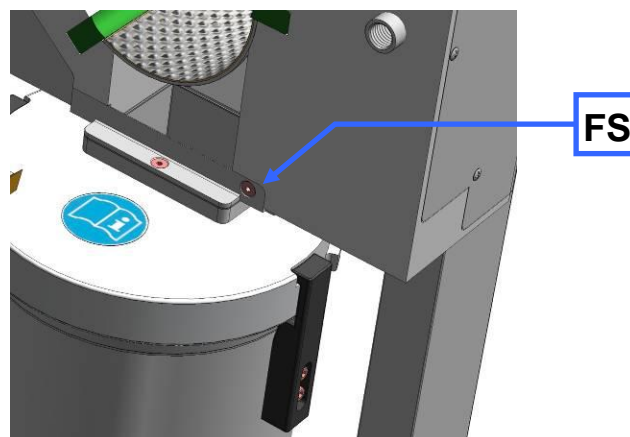

Fig. 35: Removing the discharge flange

- Loosen the screw (FS).
- Pull the discharge flange (AV) forwards out of the bracket.

7 Disposal

Please observe the respective statutory requirements with respect to disposal.

Information on disposal of electrical and electronic machines in the European Community.

Within the European Community the disposal of electrically operated devices is regulated by national provisions that are based on the EU Directive 2002/96/EC on Waste Electrical and Electronic Equipment (WEEE).

Accordingly, all machines supplied after 13.08.2005 in the business-to-business area to which this product is classified, may no longer be disposed of with municipal or household waste. To document this they have the following label:

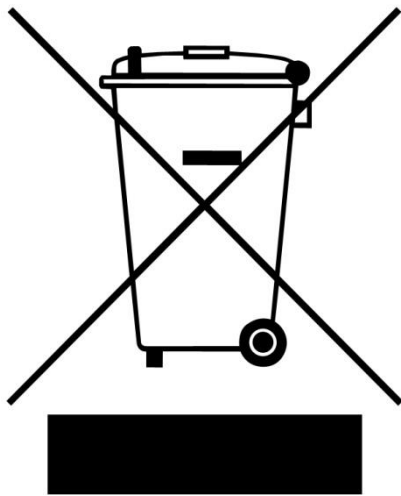

Fig. 36: Disposal label

Since the disposal regulations within the EU may differ from country to country we would request you to consult your supplier.

8 Index

A

Access to the cutting bars.....	35
Adjust the cutting gaps	36
Adjusting the cutting bars	35
Air discharge.....	33
Ambient temperature	11
Amperage	13
Atmospheric humidity	11
Attaching and removing the filter unit	33

B

Bar code	13
Bayonet lock	33
befestigen Winkel-Traversal.....	16

C

Capacity	13, 25
CE marking	13
Changes	6
Cleaning.....	37
Cleaning and service	35
Collecting receiver and filter unit	34
Confirmation	10
Connection cable	12
Copyright	6
Cutting gap	37

D

Degree of protection	25
Device	
close	31
open	31
Device designation	13
Dimensions	26
Discharge flange	33
Disposal	42
Disposal label	13
Disposal label	42

E

Electrical connection.....	12
Emissions	25
Explanations of the safety instructions	7
External fuse.....	12
Eyebolt.....	14

F

Frame	
assembly	15
Freely rotate the rotor	36
Front view	28
Fuse strength.....	13
Fuse type	13

G

General safety instructions	8
-----------------------------------	---

H

Height adjustment and alignment of the support structure	21
--	----

I

Inserting the filter unit and collecting receptacle	33
Inserting the Rotor	32
Installation	11
Installation height	21
Installation of the device	21
Installation site	
conditions	11
IP54.....	25

L

Lubrication	32
-------------------	----

M

Mains frequency.....	13
Maintenance-free	32
Manufacturer's address	13
Maximum relative humidity	11
Moderate or mild injury	7
Motor rotation speed.....	25
Motor shaft	32
Motor speed	25
Mounting the bottom sieve.....	31
Mounting the feed hopper	20, 40
Mounting the Feed Hopper	19, 20

N

Noise emission.....	25
Note on the motor	27
Notes on the manual.....	6
Number of fuses.....	13

O

Opening the grinding area door	31
Operating the device.....	28
Optimal alignment	23
Overview table of the parts of the device.....	30

P

Packaging	11
Part number	13
Power version	13
property damage.....	7

R

Rated power.....	25
Receptacle volume	25
Regulations for the place of installation	12
Removal grip.....	32
Removing the feed hopper	38
Removing the Rotor	32
Removing the transport aid.....	14
Removing the transport lock.....	19
Removing the Transport Safeguard.....	19

Repair	9	Transport.....	11
Replacing the rotor	31	Transportation aid	
Required floor space.....	26	removing.....	14
Rotary control on the motor	27	Traverse montieren.....	15
S		Type plate	12
Safety warnings	7	description	13
Schutzkappen	17	Type plate lettering	13
Serial number	13	U	
serious injury.....	7	Use of the device for the intended purpose	24
Service Address.....	9	V	
Ständer Einzelteile.....	15	Views of the instrument.....	28
Starting the grinding process	34	W	
Stopping the grinding process	34	Wear.....	32
Switching On and Off.....	34	Weight.....	26
T		Y	
Target group	8	Year of production.....	13
Technical data	24		
Temperature fluctuation and condensed water ..	11		

CUTTING MILL

SM 100 | 20.727.xxxx

EU DECLARATION OF CONFORMITY

Herewith we declare, represented by the signatory, that the above mentioned device complies with the following directives and harmonized standards:

Machinery Directive 2006/42/EC

Applied standards, in particular:

DIN EN ISO 12100	Safety of machinery
DIN EN ISO 13849-1	Safety of machinery - Safety-related parts of control systems
DIN EN 13683	Garden equipment - Integrally powered shredders/chippers – Safety
DIN EN 60204	Safety of machinery - Electrical equipment of machines

EMC Directive 2014/30/EU

Applied standards, in particular:

DIN EN 55011	Industrial, scientific and medical equipment - Radio-frequency disturbance characteristics - Limits and methods of measurement
DIN EN 61000-3-2	Electromagnetic compatibility (EMC)
DIN EN 61000-3-3	Electromagnetic compatibility (EMC)
DIN EN 61326-1	Electrical equipment for measurement, control and laboratory use - EMC requirements

Low Voltage Directive 2014/35/EU

Applied standards, in particular:

DIN EN 61010-1	Safety requirements for electrical equipment for measurement, control and laboratory use
----------------	--

Authorized person for the compilation of technical documents:

Dr. Loredana Di Labio (technical documentation)

Furthermore, we declare that the relevant technical documentation for the above mentioned device has been compiled according to Annex VII Part A of the Machinery Directive, and we undertake to submit this documentation on request to the market surveillance authorities.

In case of a modification of the device not previously agreed with Retsch GmbH, as well as the use of unauthorised spare parts or accessories, this declaration will lose its validity.

Retsch GmbH



Dr. Ing. Frank Janetta, Team Leader R&D Department

Haan, 08/2017





Retsch[®]

Copyright

© Copyright by
Retsch GmbH
Retsch-Allee 1-5
42781 Haan
Germany